

Technical features

Pilot pressure relief valves type PPI 30 are regulated from proportional solenoid which is controlled by a remote electronic card and modifies setting, changing the piloting system acting force.

By de-energised valve, flow coming from 2 is drained in 1 at a minimum setting pressure.

Operating on potentiometer through electronic card allows to act on proportional solenoid and it's possible to obtain numberless precise and repeatable adjustments.

For electronic control card technical features see from General Catalogue page n. 10.250.

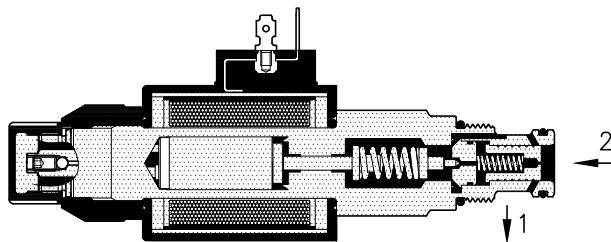
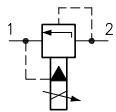

Cavity	(For dimensions see catalogue 17.000)	S 30/2
Max. flow	(l/min.)	70
Max. inlet pressure	(bar)	315
Max. pressure on line 1	(bar)	175
Fluid viscosity range	(cSt)	2.8 – 380
Fluid temperature range	(°C)	-20 +80
Max. leakage	(cm ³ /min.)	25
Mass	(kg)	0.620
Hydraulic fluid; mineral oil HM and HV ISO 6074		
Recommended filtration; 19/15 ISO 4466 (25 μ absolutes)		
Standard seals in Polyurethane and Buna N		

Nominal voltage	(Volt)	12	24
Current range	(mA)	1600	800
Nominal power	(Watt)	22	
Resistance	(Ω)	6.8	26
Insulation class	(VDE 0580)	F 155	
Rating	(ED%)	100	
Protection class	(DIN 40050)	IP 65	

Dimensions

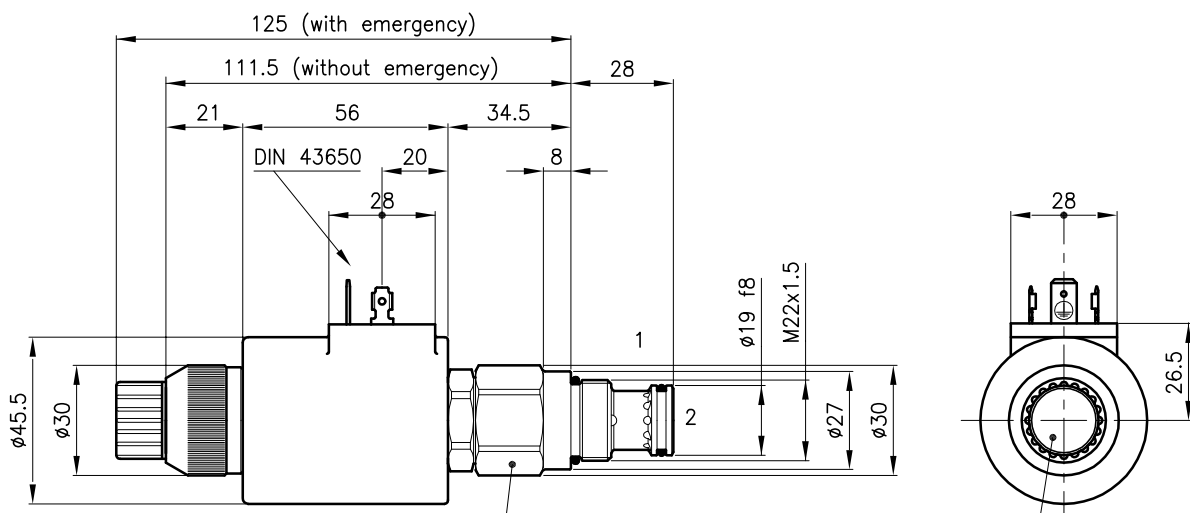

Torque 50-60 Nm
Hex. 27

Unscrew the cap to access the emergency and the air vent see catalogue 10.900

TYPICAL RELIEVING PRESSURE (2 to 1 at Various of Control Current)

Type O (5–50 bar)

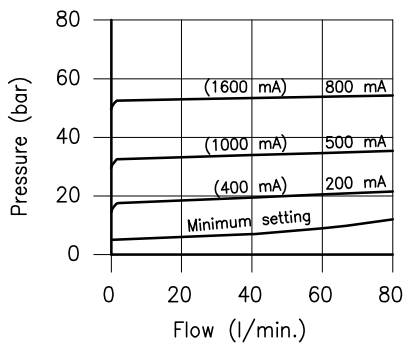

Type U (7–105 bar)

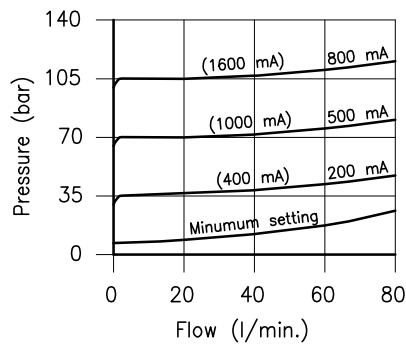

Type D (10–210 bar)

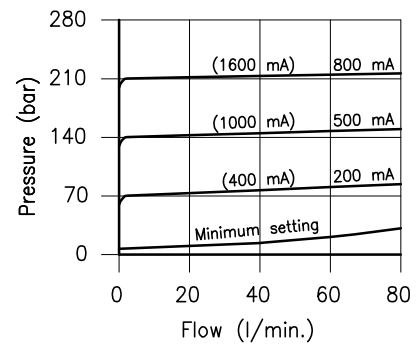

Type T (14–315 bar)

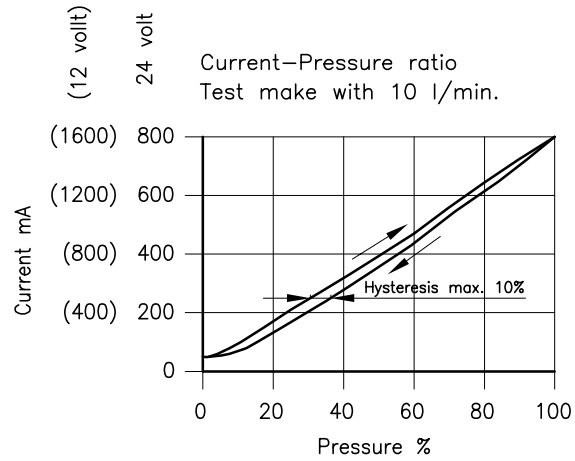
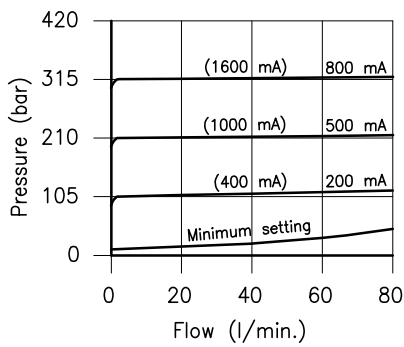

Ordering informations

PPI 30/D-24C-22H-W

PPI 30 = Valve type

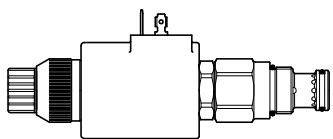

Setting range

O = 5 - 50 bar

U = 7 - 105 bar

D = 10 - 210 bar

T = 14 - 315 bar

Voltage and power

12C-22H = 12 Volt DC

24C-22H = 24 Volt DC

W = Optional without Emergency

Codes:

PPI 30/O-12C-22H 35 011 224

PPI 30/U-12C-22H 35 011 176

PPI 30/D-12C-22H 35 011 177

PPI 30/T-12C-22H 35 011 178

PPI 30/O-24C-22H 35 011 222

PPI 30/U-24C-22H 35 011 162

PPI 30/D-24C-22H 35 011 163

PPI 30/T-24C-22H 35 011 164

External seals kit 90 620 103

Code only coil:

Coil P50-24C-22H 55 125 114

Coil P50-12C-22H 55 125 113

PPI 30 valves can be assembled on standard bodies 30-LO series; for dimensions see catalogue 16.010